



# EUROPEAN PLASTICS

PLASTICS FOR THE BUILDING INDUSTRY

## Continuous Dry-Verge



**Felt Support Trays**



**Dry Ridge Kits**



**Hip Support Tray**



**GRP Dry Valleys**



**Over Fascia Vents**



**GRP Roofing**



Continuous Dry-Verge,  
Dry Fix & Roofline Building Plastics



# Continuous Dry Verge Introduction

The Continuous Dry Verge System has been specially designed to overcome the problem of water penetration at gable ends. It provides complete and continuous watertight cover for the joint between roof tiles and brickwork or bargeboard, giving greater security to the verge. Continuous Dry Verge is a fast and effective dry fix solution, without the inconvenience of using mortar and clips, providing a maintenance free, clean, attractive finish to gable ends.

Compatible with Flat, High and Low Profiled tiles, including Plain & Rosemary Tiles, manufactured by all major tile suppliers.

The 'S' Profile is compatible with interlocking slates, along with both natural and fibre cement slates.

## Composition

Ⓢ The material used is of high quality, external grade, rigid pvc, which is extremely resistant to light degradation and atmospheric pollution.

## Information

Ⓢ Manufactured in 5mtr & 6mtr lengths, in a choice of colours. A full range of connectors and ridge end caps to complement the range.

## Fitting

Ⓢ The Continuous Verge is quickly and easily fitted. No adhesive or special tools are required. Please refer to our detailed fitting instructions on pages 6 & 7, for both Slate & Tile profiles.

## Storage

Ⓢ We recommend the Continuous Dry Verge be stored horizontally, in a cool place, under cover and away from direct sunlight

## Advantages

Gives complete continuous cover against water penetration for joint between tiles and brickwork or bargeboard at gable ends. Gives greater security and added strength against wind damage by securing end tiles firmly.

- No undercloak required.
- No mortar joint required.
- No special tools or adhesives.
- Saves time and labour.
- Can be fitted in all weathers.
- Available in 5 metre and 6 metre lengths.
- Connector units available for longer runs.
- Ridge end units complete the apex.
- Gives a neater attractive line and finish to gables ends. No maintenance required
- Gives that added finish when used with uPVC bargeboards fascia and soffits.

## Colours

- Ⓢ Extruded in **Black, White, Brown, Caramel and Anthracite Grey.**
- Ⓢ 4 types suitable for use with Slate, and most Concrete Roof Tiles.



**S Type**

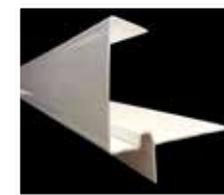

**R Type**

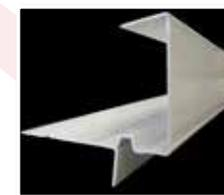

**D Type**



**M Type**



# Continuous Dry Verge Profile Dimensions

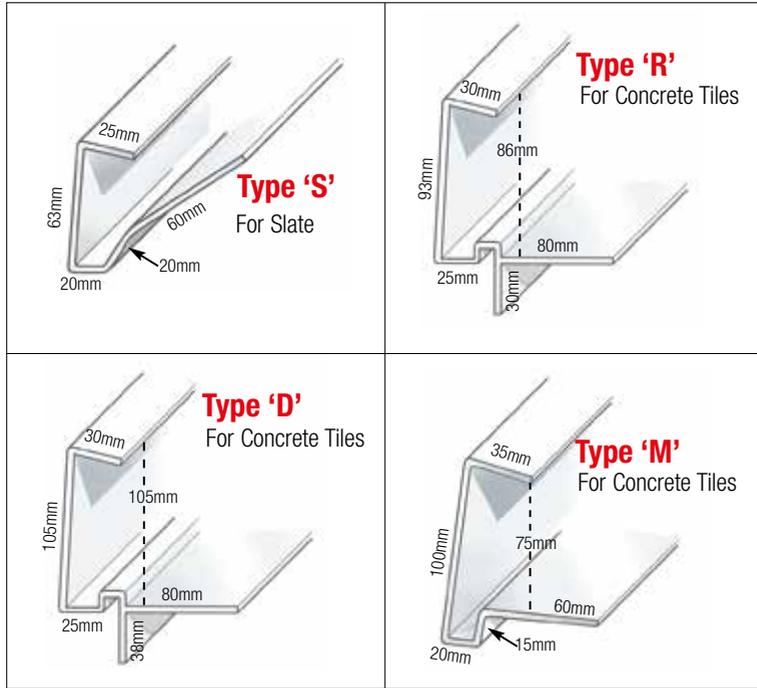

## Connectors



S Type    R Type    D Type    M Type

## Ridge End Caps

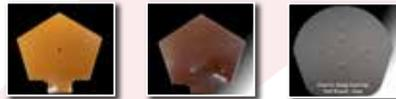

Caramel    Brown    Anthracite Grey

Length	Colour
5m & 6m	Black & White
5m	Brown, Caramel Anthracite Grey
Pack Size	
3 Per Pack	Split packs available



# Profile Compatibility Table Tile & Slate

For use with a 25mm batten	Manufacturer Name	Tile Name
<b>R TYPE</b>	<b>MARLEY</b>	Ludlow Plus; Eco, Std Ludlow Major; Modern; Duo Modern; Plain Tile; Clay Plain Tile Range; <b>Ashmore; Edgemere Range (See below on Bold products)</b>
	<b>REDLAND</b>	49 Tile; Renown; Landmark Double Roman; 50 Double Roman; Stonewold MK2; Mini Stonewold; Mockbond Mini Stonewold; Rosemary Tiles; Plain Tile; Heathland Plain; Duo Plain; <b>Richmond; Mockbond Richmond; Landmark 10; Saxon 10; (See below on Bold products)</b>
	<b>SANDTOFT</b>	Standard Pattern; Calderdale; Dual Calderdale; Lindum; Plain Tile; 20 20; <b>Actua; Vauban; Rivius; Cassius; (See below on Bold products)</b>
	<b>RUSSELL</b>	Cheviot; Grampian; Highland; Plain Tile; <b>Galloway; Lothian; Moray; Polden; (See below on Bold products)</b>
	<b>FORTICRETE</b>	Centurion; V2; Senator; Hardrow; Plain Tile; <b>Gemini; Mini Slate; (See below on Bold products)</b>
	<b>QUINN</b>	Western Slate; <b>Rathmore; Devenish; (See below on Bold products)</b>
<b>D Type</b>	<b>MARLEY</b>	Double Roman; Mendip; Wessex; Anglia; Clay Pantile; Clay Double Roman
	<b>REDLAND</b>	Regent; Grovebury; Landmark Double Pantile; Clay Pantile Range
	<b>SANDTOFT</b>	Double Pantile; Double Roman; Shire Pantile; Modula Range; Olympus;
	<b>RUSSELL</b>	Argyll; Pennine; Double Roman;
	<b>QUINN</b>	Locherne
<b>S Type</b>	<b>MARLEY</b>	Rivendale; Birkdale; Garsdale; Thrutone
	<b>REDLAND</b>	Cambrian
	<b>SANDTOFT</b>	Britlock; Britslate
<b>M type may be used on Bold Items; (based on maximum Batten Gauge &amp; Tile Lap)</b>		

## Continuous Dry Verge Tile Profile Fitting

The Continuous Dry Verge should be cut to the required length, allowing for a plumb cut at the ridge, and approximately 150mm longer than the rafter. The horizontal flange is cut away, to allow fitting over the felt support tray at the eaves.

The battens are placed against the lip of the water channel of the dry verge, which are then nailed into position directly through the horizontal fin of the Verge. The nails are fixed through both batten and verge, into the timber rafter. A close-up of the roof battens in place show their position against the lip of the drainage channel.

Once all the battens are fixed in place, and the Dry Verge secure, the roof is ready for tiling. The roof tiles are fitted in the usual manner, ensuring that the verge tiles are fully inserted into the verge, where the top flange will hold them firmly in place.

At the eaves, the verge should be cut square, flush to the lower tile, and notched into the gutter. **Eaves stop ends** are available for closing the eaves on the 'R' and 'D' profiles. The water channel allows any rainwater to run directly into the rainwater gutter.

The fitted Continuous Dry Verge achieves a professional finish. This will be similar for any roof tile or slate being used. The completed roof gives complete continuous cover against water penetration, and added strength from wind damage by securing end tiles firmly.



## Continuous Dry Verge Slate Profile Fitting

The roof battens are fixed in place to the required slate gauge, however, the batten ends are not fixed in place as yet, to allow the 60mm flange of the slate verge to be fitted under the batten, which is the easiest way to fit in place.

The roof battens ends are then securely fixed in place, by nailing through both batten and verge, into the timber rafter.

The slate verge profile is then at an angle, which is manufactured in that way, so the top flange clamps down on any thickness of slate, from a 5/6mm general slate to 12/13mm natural slate.

To open the external face of the slate verge, a temporary batten is placed between the batten courses, which is pushed against the inner face of the slate verge, and nailed in place. This opens the profile of the verge to a vertical position.

The slates are fixed in place in the usual manner, with the outer edge of the slate fixed against the internal edge of the verge.

This will hold the verge in the vertical position, and continue this procedure in the normal manner up the verge of the roof.

The Continuous Slate Dry Verge achieves a professional finish. This will be similar for any slate being used. The completed roof gives complete continuous cover against water penetration, and added strength from wind damage by securing end slates firmly.



# UNIVERSAL DRY VERGE - Installation

## Description & Use

The Ultimate universal, high speed, high quality easy install dry verge. Left and right handed units are no longer required as our verge is truly universal. The unique design is quick and easy to install on most tiles and has exceptional holding qualities. A tight secure fit is easily achieved ensuring roof tiles are held firmly in place and not vulnerable to wind dislodgement.

## Benefits

-  Universal handed units, suits both sides of the roof
-  Tight secure fix, not vulnerable to wind dislodgement
-  Flexible polypropylene material allows for rapid installation
-  Can be installed in any weather condition
-  Weather resistant and UV Stable

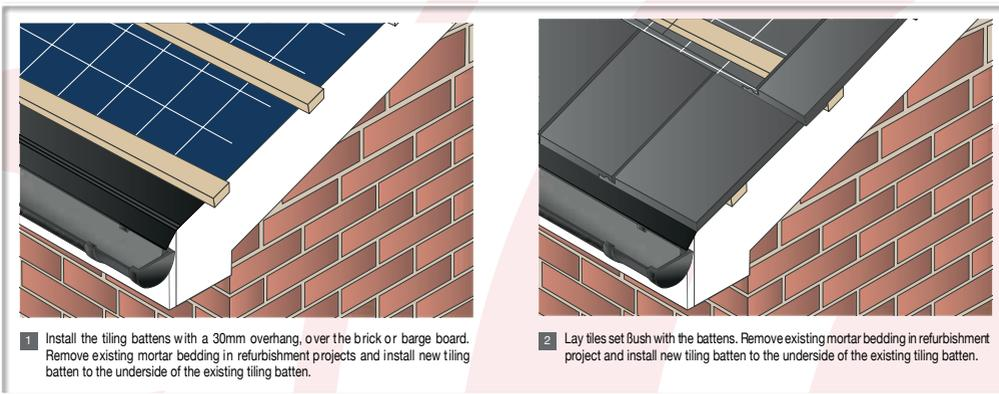

# UNIVERSAL DRY VERGE Installation - Continued

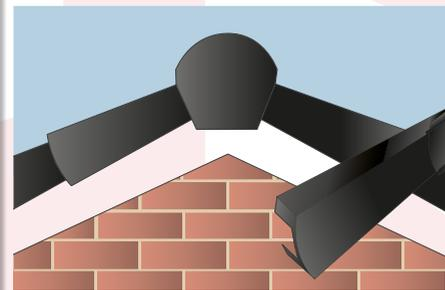
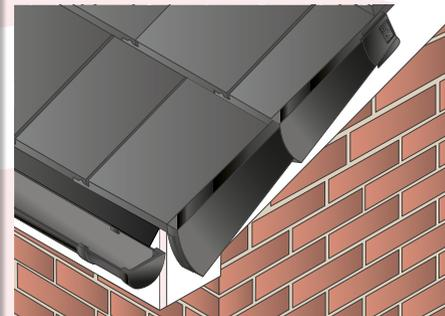
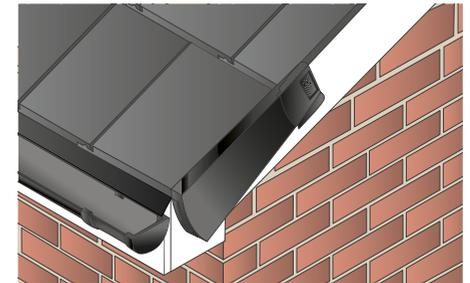

Flapcap Technology incorporates flexible flaps on the Ridge Cap that contour around the side of the verge unit, effectively creating a sealed unit that prevents water ingress and infestation.

# UNIVERSAL DRY VERGE & Accessories

### Universal Verge Unit

410mm  
150mm  
125mm  
165mm  
90mm  
137mm

Profile at widest  
Profile at narrowest

**Weight**  
0.20kg per Single

### Ridge Caps

#### Half Round Ridge Cap

260mm  
240mm  
190mm

**Weight**  
0.11kg per Single

#### Angled Ridge Cap

267mm  
240mm  
190mm

**Weight**  
0.18kg per Single

### Starter & End Cap

Blanking Plate  
Starter

**Weight**  
0.13kg per Single

### FlapCap TECHNOLOGY

Flexible flaps on the Ridge Cap contour around the side of the verge unit, effectively creating a sealed unit that prevents water ingress and infestation.

# UNIVERSAL DRY VERGE Starter and End Cap

### Universal Verge Unit

410mm  
150mm  
125mm  
165mm  
90mm  
137mm

Profile at widest  
Profile at narrowest

**Weight**  
0.20kg per Single

### Starter & End Cap

Starter  
Blanking Plate

**Weight**  
0.13kg per Single

## Description

Our unique starter unit includes a verge-end closure and a blanking cap to ensure a secure, infestation free and aesthetically pleasing finish. For use in both new build and refurbishment application, the unit is UV stable and comes in all colours.

## Benefits

- Ensures an infestation free and aesthetically pleasing finish to the dry verge
- Weather resistant and UV Stable

## Installation

Snap the starter kit off the blanking plate. Starting at the bottom edge of the roof, insert the starter piece into the front end of the verge unit, mark out the starter piece position on the fascia and barge board. Remove the dry verge U and mechanically fix the starter piece into position through the grid. Refer to Dry verge product information sheet for further information on our Dry Verge system. Where required, insert the blanking plate over the final verge nail grid to prevent water ingress.

**Colours :** Grey, Brown, Black and Terracotta

**Material:** Polypropylene

**Other related products:** ¥ Universal Dry Verge  
¥ Ridge End Caps & FlapCap Technology

# Eaves Protection (EPS) Felt Support Trays

The Eaves Protector has been designed to provide a long term solution to the problems associated with eaves decay under the roof, including the degradation of felt and the secondary rotting of rafter timbers and other roof structures.

Roofing felt perishes over a period of time, and is at its most vulnerable at the lower end, the eaves. This is where the felt can sag and water can collect, this is called 'ponding'. After some-time the ponding effect causes the felt to rot and rupture, allowing the water to access the roofing system.

The Eaves Guard/Felt Support Tray, which is plastic, prevents this as it is rigid enough to prevent the overlapping felt to sag or pond, and so avoids the natural breakdown process.

The Eaves Guard is the most cost effective way of providing a complete and robust felt support system that will not deteriorate, giving additional protection to the fascia detail, and suitable for use with all slates and tiles.

## Installation

Position the eaves guard on top of the fascia board and nail in place. Adjacent trays are designed to lap over each other, minimum of 100mm, easily forming a continuous run. The trays should sit on top of the over fascia vent, if fitted; a comb filler may also be fixed at the same time. The felt underlay should be pulled tight to ensure there are no troughs that can retain any water. Ensure the felt finishes before the fascia, therefore it is not exposed to the elements, and is not subject to decay.

The Eaves Protection System is designed for use in both new build and refurbishment, which provides an effective level of eaves protection, and fitted with the minimum of disruption.

The Eaves Protection System is ideal for use with the new generation of lightweight, high performance underlays, which are not suitable for forming a drip into the gutter.

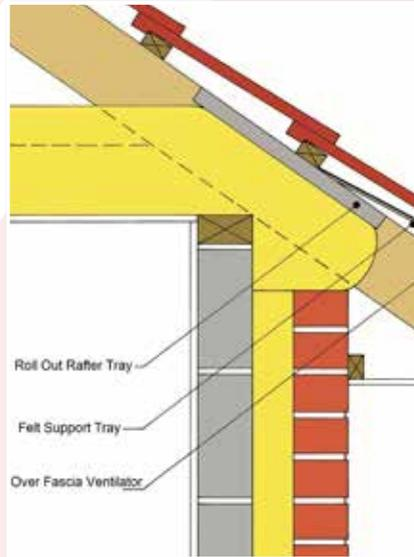

<b>SIZE</b>	1500mm Long
<b>MATERIAL</b>	Re-constituted pvc
<b>PACK SIZE</b>	Pack of 10; Pallets of 500 & 1000
<b>WEIGHT</b>	Pack of 10 : 10kg
<b>BENEFITS</b>	Lightweight; quick & easy to install; durable.

# OVEP : Over-Fascia Vented Eaves Protection

A further development of eaves protection comes in the form of the innovative 'one-piece' eaves protector combined with an integrated over fascia ventilator and bird comb.

The 'one-fix' system is provided by an upstand on the underside of the eaves protector, which sits on the top edge of the fascia board, which is supplied with a 10mm continuous vent.

Known as a '**2 in 1**' System, used with Flat Tiles and Slates.

The provision of a fixed bird comb creates an effective barrier against birds and large insects, which is known as a '**3 in 1**' System, used with all Profiled tiles.

## Installation: New Build

The OVEP is located onto the top of the fascia board, ensuring the stop beads, below the vent, are rested against the front face of the fascia board. When using a slate or flat tile, where a comb filler is not required, the OVEP is fitted using a minimum 50mm corrosion resistant fixing through the nail/screw ports, ensuring both ends are securely fixed. Locate the OVEP onto the interlocking section of the previous board, fixing in place. Continue this process along the whole length of the eaves.

## Installation: Existing/Retro Fit

For refurbishment work, the installation is very similar. Remove or lift the eaves course and make good any damage to the rafters and underlay. The OVEP is fitted in place as above, and the existing underlay relayed on the OVEP. The tiles or slates are the replaced.



<b>SIZE</b>	1000mm long x 200mm cover width
<b>MATERIAL</b>	UV stable polypropylene, 100% re-processed
<b>PACK SIZE</b>	'2 in 1' - 40 per box '3 in 1' - 20 per box
<b>REGULATIONS</b>	NHBC requirements: Complies with BS5250: 2002
<b>BENEFITS</b>	Combined Vent and Felt Support Tray, Strong, Durable, 15 year guarantee, Suitable between 15 & 70 deg. pitch

**Fast Fix Verge**



**Dry Fix Valley**



**Abutment Soaker**



**Dry Ridge**



**Slate Valley**



**Rafter Roll**



**Hip Support Tray**



**Felt Support Tray**



**Over Fascia Vent**



**OVEP 3in1**



**Continuous Dry Verge**



# Eaves Ventilation

## Over Fascia Vent 10mm & 25mm

To comply with building regulations (approved document F2) all newly built properties must have continuous ventilation at eaves level to avoid damp and condensation within the roof void. Inadequate ventilation to the loft will cause structural damage to the roof timbers. Good loft ventilation is essential to remove moist air from the loft space, and ensures continuous airflow throughout the roofing system, thereby allowing the roof to 'breathe'.

Fitted on the top edge of the fascia board, this gives a clean and unbroken 10mm continuous air gap along the eaves.

<b>SIZE</b>	1000mm long, 21mm high, (10mm OFV) 1000mm long, 32mm high, (25mm OFV)
<b>MATERIAL</b>	Co-Polymer Polypropylene
<b>PACK SIZE</b>	10mm - 60 per box    25mm - 50 per box
<b>BENEFITS</b>	Low profile design, lightweight, 4mm integral grill, fixing location holes., Extremely strong, resists the weight of tiles



# Eaves Ventilation

## Roll Out Rafter Trays

Many of the present continuous type roll panel ventilators are susceptible to collapse when installed due to their manufacturing method, box-like shape and poor design characteristics. The European Plastics Roll Panel Ventilator has been designed with better rigidity, to avoid collapsing when installed over the insulation. The robust sinusoidal shape of the ribs provides additional strength and ensures that when fitted over the wall plate, the ventilation to the roof space remains unobstructed.

The new widths also ensure that when fitted with the new higher levels of insulation, the ends of the ventilators are not blocked. The Roll Out Trays will provide a clear ventilation channel above the loft insulation, and provides continuous ventilation when installed along the whole length of the eaves.

### Installation

The Roll Out rafter trays are positioned over the rafters, and are designed to fit rafter centres of 400mm, 450mm and 600mm. Once in position, they will provide a clear ventilation channel over the roof insulation and fixed into the rafters with corrosion resistant fixings.

The Roll Out Trays are an effective way of preventing the loft insulation from being pushed to the underside of the roofing felt, which then maintains a clear ventilation path into the roof void from the eaves

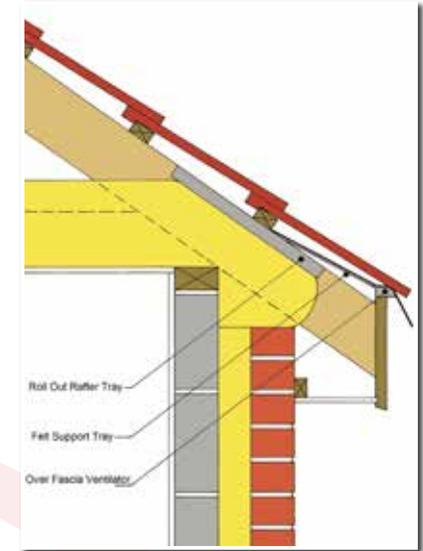

## Eaves Comb Filler



The Eaves Comb Filler (Bird Comb) creates a barrier against birds and large insects. It prevents them entering the void between the underside of Profiled Tiles and the underlay on pitched roofs. Injection moulded from high quality, low density polyethylene. It's flexibility prevents any alignment problems. Manufactured in 1.0mtr strips, which is effective, quick and easy to fit. Durable and totally resistant to decay.

<b>SIZE</b>	1000mm long, 55mm deep
<b>MATERIAL</b>	Low density polyethylene
<b>PACK SIZE</b>	300 per box (supplied in split packs of 100)
<b>BENEFITS</b>	Convenient 1mtr lengths, quick & easy to fit

## Disc Vent - 70mm



The DSV (Circular Disc Vent) is designed to provide ventilation through new or existing soffit boards, whilst preventing entry of insects with the use of a 4mm grid.

<b>SIZE</b>	70mm diameter
<b>MATERIAL</b>	Polypropylene (UV Stabilised)
<b>PACK SIZE</b>	100 per box
<b>COLOURS</b>	White, Black & Brown



<b>WIDTH SIZE</b>	300mm, 400mm, 600mm, 800mm
<b>LENGTH</b>	6mtr Roll
<b>PACK SIZE</b>	10 rolls per Box
<b>MATERIAL</b>	Black pvc
<b>BENEFITS</b>	Universal Rafter Fitting, Lightweight, Durable, Reduces the risk of cold bridging

# V-Flow GRP Bonding Strip Jointing Strip (Secret Valley)

**GRP Bonding Strip** is manufactured from glass fibre/polyester laminate with a UV-resistant polyester film on the upper face. A sanded strip is bonded along the upper face to provide a key for bedding the roof tiles into mortar.

The Bonding Strip gives a weatherproof seal between adjacent roofs. Joins any combination of double lap or interlocking slates, clay or concrete tiles, with minimum disturbance to the adjacent roof.

The packs should be stored flat or on end, on a smooth, clean, dry surface; under cover and protected from sunlight.

### Installation

The end tiles/slates on both roofs should be removed to expose the construction over the party wall. Before fitting, it is advisable a fire stop is fitted to the top of the party wall, to ensure that fire cannot spread between the 2 buildings.

Starting from the eaves, lay and fix the bonding gutter using clout head nails at approx. 1m centres, ensuring the sanded strip is situated centrally over the party wall. Consecutive lengths of the jointing strip requires a minimum lap of 150mm.

A mortar bed is applied to the sanded strip. The slates or tiles are fixed on both sides, ensuring they are located and butted up centrally over the bonding gutter. Ensure the mortar does not enter the water channel of the slate or tile.

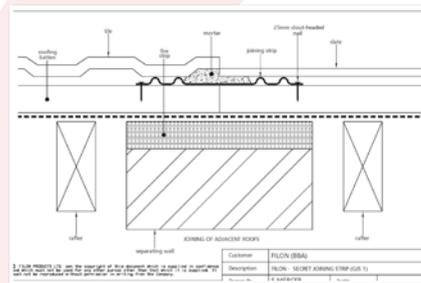
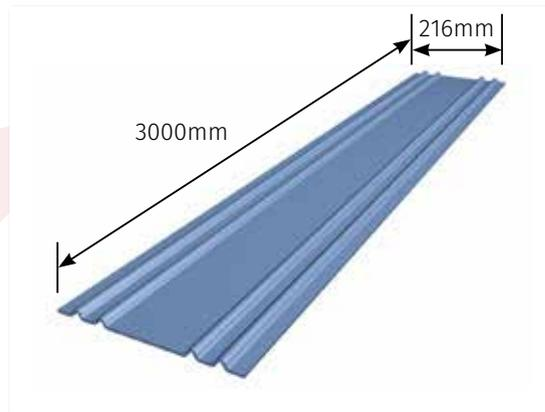
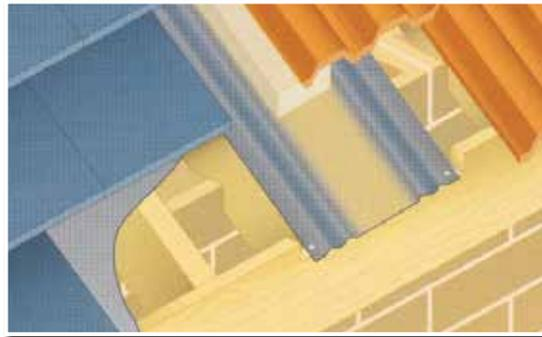

<b>SIZE</b>	3000mm long x 216mm wide
<b>MATERIAL</b>	UV Glass fibre/Polyester laminate. BBA
<b>PACK SIZE</b>	10 per pack . 16kg per pack
<b>PRODUCT CODE</b>	EP-GJS1
<b>BENEFITS</b>	Lightweight and flexible. UV Resistant, Provides a weather tight seal between adjacent roofs with different finishes.

# V-Flow GRP Abutment Soaker Secret Gutter (Unlipped)

**GRP Abutment Soaker** is manufactured from glass fibre/polyester laminate with a UV-resistant polyester film on the upper face. A sanded strip is bonded along the upper face to provide a key for bedding the roof tiles into mortar.

The Abutment Soaker gives a weatherproof protection seal between a sloping roof and a vertical abutment. The two bars on the section prevent moisture from entering the roof space.

### Installation

The roof underlay is laid as in normal practice, with the underlay finished and turned approximately 100mm up the abutting walls. Battens should be cut 50mm short of the abutment wall and nailed to the rafter, using clout head nails. Noggins may be needed to be fixed flush to the top of the rafters to anchor the battens. The soaker is nailed at 500mm centres to the roof battens. At the ridge, the abutment flashing should be mitred and dressed with a Code 4 lead.

It is advisable to use double slates/tiles to eliminate the possibility of small sections require fixing. Where tiles are used, these should be bedded onto mortar which is applied onto the sanded strip running along the length of the product. It may be necessary to break off the nibs of concrete tiles to eliminate a kick-up. Code 4 lead stepped flashing is used to dress over the abutment flashing upstand. It may be necessary to trim the fascia board to allow any water to be discharged into the rainwater gutter. Alternatively, a tilting fillet may be used.

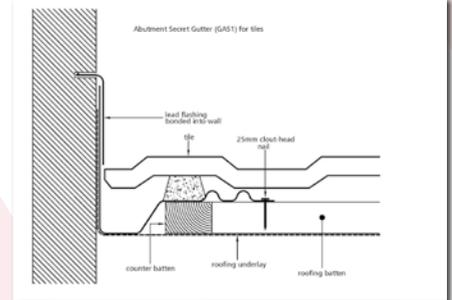
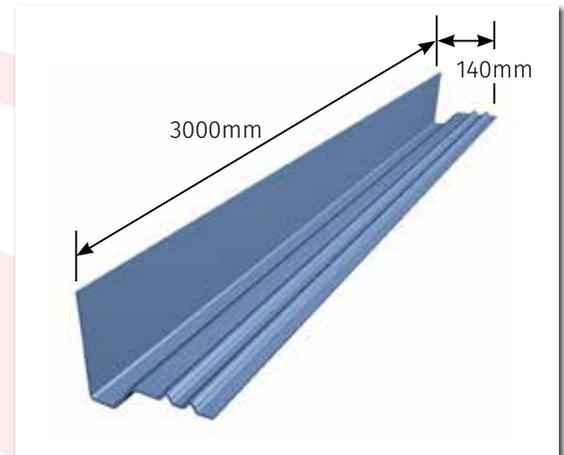
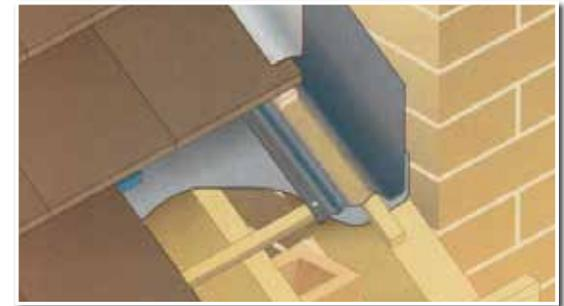

<b>SIZE</b>	3000mm long x 140mm wide
<b>MATERIAL</b>	UV Glass fibre/Polyester laminate. BBA
<b>PACK SIZE</b>	10 per pack . 17kg per pack
<b>PRODUCT CODE</b>	EP-GAS1
<b>BENEFITS</b>	Lightweight and flexible. UV Resistant, Provides weatherproof protection between a sloping roof and a vertical abutment.

# V-Flow GRP Valley Trough Slate Valley (Standard Fixing)

The **GRP Slate Valley** is a modern cost-effective alternative to using a traditional lead valley when used with natural and man made slate coverings.

At a fraction of the cost and weight of lead, GRP valleys are supplied in convenient 3mt lengths, which are easy to transport and handle on site. GRP products are easy to cut, and sufficiently flexible to allow for a variety of roof pitches.

GRP valley troughs are manufactured from a lead grey, glass reinforced polyester, and applied with a UV inhibiting film to the external surface.

## Installation

Valley boards should be fitted of sufficient width to provide support for the roofing battens, and must be flush with the top of the rafters; or a 6mm ply-wood laid over the rafters.

The valley is first lined with a strip of roofing underlay along the length of the valley, to be 1mt wide.

A length of valley should be pressed into the valley and marked with a chalk line, where a longitudinal batten will be fixed as support for the edge of the valley.

Starting at the base of the valley, the troughs should be nailed onto the longitudinal batten with large head clout nail at 500mm centres, through pre-drilled 8mm holes.

Consecutive lengths of valley should have a minimum overlap of 150mm. At the top of adjoining troughs, the units should be mitred and dressed with a code 4 lead saddle. The fascia board may need to be trimmed to ensure full water flow into the rain water gutter.

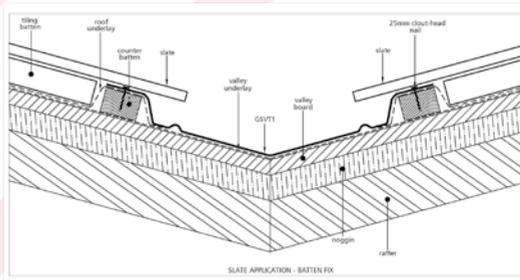
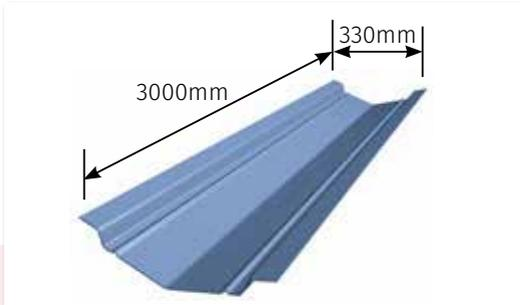

<b>SIZE</b>	3000mm long x 330mm wide
<b>MATERIAL</b>	UV Glass fibre/Polyester laminate. BBA
<b>PACK SIZE</b>	10 per pack . 19kg per pack
<b>PRODUCT CODE</b>	EP-GSVT1
<b>BENEFITS</b>	Cost-effective alternative to lead. Life expectancy of over 30 years. Lightweight, flexible and easy to transport.



# V-Flow GRP Valley Trough Tile Valley (Standard Fixing)

**GRP Tile Valley** (360mm), is the modern cost-effective alternative to using a traditional lead valley when used with concrete or clay roof tiles. At a fraction of the cost and weight of lead, GRP valleys are supplied in convenient 3mt lengths, which are easy to transport and handle on site. GRP Valleys are easy to cut, and sufficiently flexible to allow for a variety of roof pitches.

A 400mm wide valley is available for longer runs and a wider valley;

A 400mm Flat Fixing valley is available when using sarking boards.

## Installation

Valley boards should be fitted of sufficient width to provide support for the roofing battens, and must be flush with the top of the rafters; or a 6mm plywood laid over the rafters.

The valley is first lined with a strip of roofing underlay along the length of the valley, to be 1mt wide. A length of valley should be pressed into the valley and marked with a chalk line, where a longitudinal batten will be fixed as support for the edge of the valley.

Starting at the base of the valley, the troughs should be nailed onto the longitudinal batten with large head clout nail at 500mm centres, through pre-drilled 8mm holes.

Consecutive lengths of valley should have a minimum overlap of 150mm. At the top of adjoining troughs, the units should be mitred and dressed with a code 4 lead saddle. The fascia board may need to be trimmed to ensure full water flow into the rain water gutter.

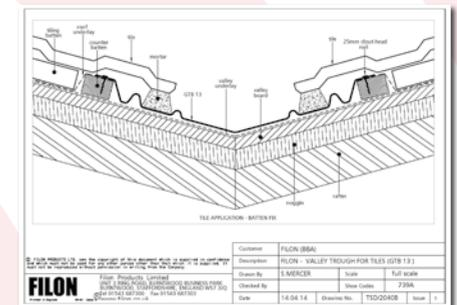
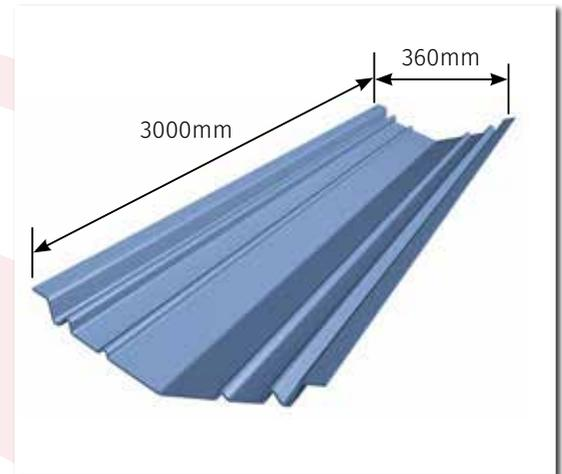

<b>SIZE</b>	3000mm long x 360mm standard width
<b>MATERIAL</b>	UV Glass fibre/Polyester laminate. BBA
<b>PACK SIZE</b>	10 per pack . 24kg per pack
<b>PRODUCT CODE</b>	EP-GTB13
<b>BENEFITS</b>	Cost-effective alternative to lead. Life expectancy of over 30 years. Lightweight, flexible and easy to transport.

Customer:	FILON BBA
Description:	VALLEY TROUGH FOR TILES (GSV 13)
Drawn By:	SLANDER
Checked By:	Sheela
Date:	14.04.14
Drawn No.:	TSD00408
Scale:	1:1

# V-Flow GRP Dry Valley

## High & Low Profile

A **GRP Dry Valley** is a mortarless system which provides a maintenance free means of discharging water from the roof, which is suitable for use with slates, interlocking and profiled roof tiles.

The Dry Valley is supplied in 3m lengths, in **Low**, **Mid** and **High** profiles, depending on the roof covering being used. They can be fixed as an **Under Batten** profile (Fig. 1), or as an **Over Batten** profile (Fig. 2). They are finished in a standard lead grey colour.

The Dry Valley creates a close-cut appearance on a new build and refurbished properties where fixing times can be cut by up to 50% over traditional methods.

### Eaves Closures and Top Closures

Eaves Closures and Top Closures are used for overlaying on the ends of GRP valleys, which give a clean finish, and alternative to lead or mortar, which are manufactured from a flexible and durable polyurethane.

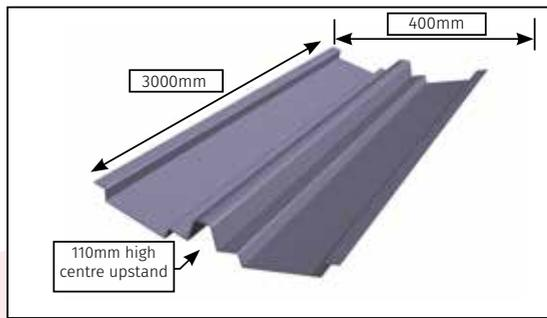

**Under batten Dry Valley**

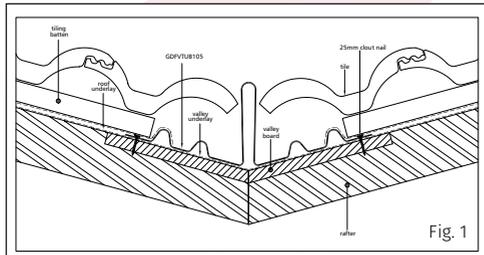

Fig. 1

**Over batten Dry Valley**

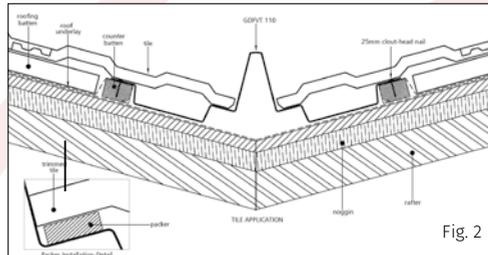

Fig. 2

PROFILE	UNDER BATTEN FIXING			OVER BATTEN FIXING	
SIZE	3000mm long x 400mm wide			3000mm long x 400mm wide	
MATERIAL	UV Glass fibre/Polyester laminate.			UV Glass fibre/Polyester laminate	
PACK SIZE	10 per pack			10 per pack	
PACK WEIGHT	55mm (21KG)	80mm (26kg)	105mm (30kg)	70mm (26kg)	110mm (32kg)
PRODUCT CODE	55mm: EP-TUB55	80mm: EP-TUB80	105mm: EP-TUB105	70mm: EP-GDFV70	110mm: EP-GDFV110
BENEFITS	Improved Drainage. No Mortar. Improved Appearance. Time saving				

# V-Flow GRP Dry Valley

## Eaves and Top Closure

The GRP Valley Troughs are suitable for roof pitches up to 60 degree, and strongly recommend that plywood or timber valley boards should be used. The underlay and battens are fitted as standard practice, with a batten running the length of the valley on each side to accommodate the external raised water bar section.

When using the Eaves Closure, the 150mm long GRP pre-cut valley section support should be positioned close to the eaves (Image 1). The eaves closure piece should be overlaid onto the GRP pre-cut valley section (150mm overlap), ensuring the GRP valley edges are positioned over the longitudinal battens (Image 2). At the highest point, fix with a large headed clout nail into the longitudinal batten.

The Valley Troughs are fitted onto the valley boards and firmly fixed from the eaves closure section upwards, (Image 3). Using suitable large headed roofing nails on either side of the trough and through the top flat section of the water bar, at a minimum of 500mm centres.

All overlaps should be at least 150mm, and care should be taken to ensure the central raised section is not distorted, and positioned central to the valley. If the valley trough finishes with a corresponding valley at the ridge, the top closure piece can be used. These closure sections overlap the valley troughs and underlap the slates or tiles that form over this point. (Image 4)

The longitudinal battens of each valley should meet and be mitred so that the top of the top closure can be fixed with a suitable roofing nail to stop any movement. The top closure then overlaps both valley troughs by 150mm and forms a neat, tidy waterproof seal. (Image 4)

Tiles or Slates can now be laid into and over the troughs. When cutting the tiles or slates, it is important that neither should be forced to fit, in case of distortion to the central upstand. In some instances small cuts will be required, and self adhesive packers are supplied with the valley to support these small cuts if required (see the detailed x-section on page 20)

When slating or tiling is complete, the eaves closure section should be cut with a sharp knife or scissors to allow water to discharge into the rainwater gutter. It is important to ensure that the valley troughs are cleared of any debris on completion, so water flow is not impeded.

**Top Closure DFVTC070, DFVTC110**  
**Eaves Closure DFVTC570, DFVTC5110**

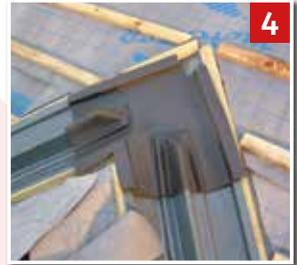

# V-Flow GRP Dry Bonding Strip

## High & Low Profile

A GRP Dry Bonding Strip is a mortarless system which creates a weather tight joint between dissimilar roof coverings on adjacent roofs, and joins any combination of slates or flat and profiled tiles.

The Dry Bonding Strip is supplied in 3mt lengths, in **70mm (Low)** and **100mm (High)** profiles, depending on the roof covering being used. They are finished in a standard lead grey colour, and are BBA Letting air through. Keeping moisture out!

The Dry Bonding Strip creates a close-cut appearance on refurbished properties where fixing times can be cut by up to 50% over traditional mortar methods.

Packs should be stored flat or on end on a smooth, clean dry surface; under cover and protected from sunlight.



70mm Dry Bonding Strip

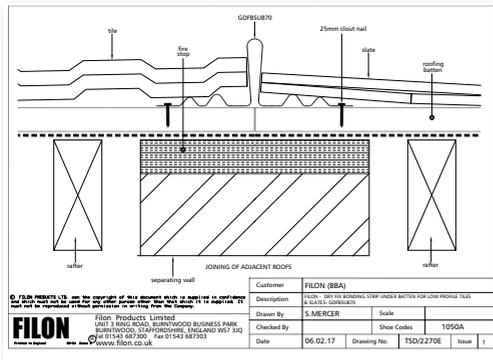

100mm Dry Bonding Strip

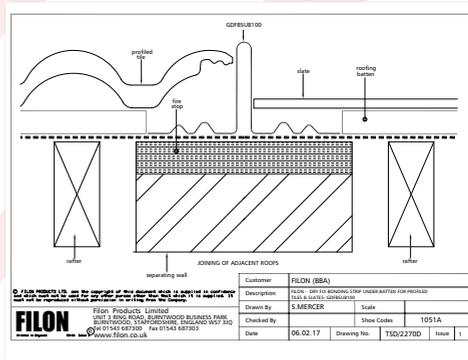

# Universal Dry Ridge

## Introduction

The Universal, Ventilated Dry Ridge System is a High Quality, Low Cost System, in 6mtr Packs. Suitable with Half Round & Angle Ridge Tiles (Concrete & Plain Clay). Pumped, not taped, Butyl has greater adhesion, which creates a Quality Water Seal. The Universal Ridge Unions & Adjustable 'Ratchet' clips, have greater Strength & Flexibility, which means plain clay and concrete ridge tiles are no problem for the Easy Ridge System.

High Quality 100mm Stainless Steel Screws & Fixing Brackets, ensures long term durability of the Universal Dry Ridge System.



**SIZE** 6mtr Packs

**OPTIONS** Hip Kits available; Hip Support Tray

**MINIMUM QTY.** 1 Box (Accessories page 26)

**FEATURES** Universal - Concrete & Clay Tiles

**BENEFITS** Quick & East to install.



<b>SIZE</b>	3000mm long x 225mm wide	
<b>MATERIAL</b>	UV Glass fibre/Polyester laminate.	
<b>PACK SIZE</b>	10 per pack .	
<b>PACK WEIGHT</b>	Low Profile 70mm (16kg)	High Profile 100mm (21kg)
<b>PRODUCT CODE</b>	70m= EP-SUB70	100mm= EP-SUB100
<b>BENEFITS</b>	Improved Drainage. No Mortar. Improved Appearance. Time saving	



# Dry Ridge Installation

## Step by Step Guide



1. Install the underlay and battens as normal, leaving the underlay 5-30mm short of the ridge on both sides. Do not fix the top tiling batten at this stage.



5. Roll out the ridge roll centrally across the entire length of the ridge batten, using the white spine of the roll as a guide over the ridge batten. Secure the roll by nailing or stapling through the white spine. All joints must be overlapped by 75mm min. Leave a 75mm long strip of the roll at each end of the ridge.



2. Place the ridge batten brackets across the apex of the roof, and nail to the rafters on both sides of the roof, using the nails provided, which can be fixed at 450mm & 600mm centres. Install the top tiling batten as normal, leaving a 10mm gap before the ridge batten.



6. Remove the release paper from the butyl adhesive strip on the underside of each edge of the ridge roll, and firmly press onto the clean dry tile on both side, avoid crushing the corrugations. Continue this process along the entire ridge line. Adhere the roll to the vertical surface of the dry verge at the gable end and at the hip abutment, overlap the roll across the hip rolls by 75mm, carefully sealing the butyl adhesive in place.



3. Place the first ridge batten in the batten bracket, and nail through the holes provided in the flange. Build up the ridge batten to the required height by adding one or two more battens, nailing each to the previous batten to ensure it is adequately secured in place.



7. Loosely insert the long ratchet clip and two short ratchet clips respectively into the middle and side slots on the union. Lay the ridge tile on the ridge roll, starting at the gable end or hip abutment, and slide the next ridge tile into the open end of the ridge union and press all three clips firmly in place. Secure the union with the screws provided, through the long ratchet clip.



4. Lay and fix the roof tiles as normal



8. Continue this process along the ridge to the end. Secure the ridge end tile through the pre-drilled holes provided, or drill a hole through when using a reclaimed tile.

# Dry Hip Installation

## Step by Step Guide

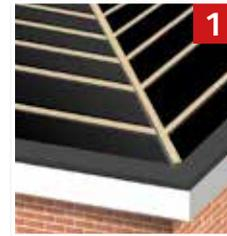

1. Lay the underlay as normal, ensuring that the underlay overlaps the other side by 150mm min. Install the tiling battens to the hip rafter, or to the noggins nailed to the hip rafter.



5. Remove the release paper from the butyl adhesive strip on the underside of each edge of the roll, and firmly press onto the dry, clean tile on both sides, avoid crushing the corrugations. Ensure the rolls overlap at the hip abutment, and at the eaves carefully tuck back and stick behind the tiles.



2. Build up the hip batten on the hip rafter, to a height such that the hip tray overlaps the tiles on both sides and secure with nails.



6. Lay the Hip Trays centrally over the hip roll, overlapping the next tray by a minimum of 75mm and secure with galvanised clout nails.



3. Lay tiles as normal, ensure neatly cut tiles are no more than 30mm from the battens, and secured using the long and short **Hip Clips** provided. Nail the long hip clip to the batten and then slide the cut tile into the clip below. Clip the short clip to the top end of the cut tile, attaching it to the adjoining tile at the interlock.



7. Loosely insert the long ratchet clip and two short ratchet clips respectively into the middle and side slots on the union. Lay the block end hip tile on the ridge roll, starting at the eaves. Mechanically fix with a screw and washer, and slide the union into the open end of the ridge tile. Slide the next hip ridge into the open end of the union and press all three clips firmly in place. Secure the union with the screws provided, through the long ratchet clips. Any protruding end of the union can be snapped off or folded behind the union.



4. Roll out the ridge roll centrally along the entire length of the ridge batten, using the white spine of the roll as a guide. Secure the roll by nailing through the white spine using the galvanised nails provided. All joints along the ridge roll must have a minimum overlap of 75mm. Leave a 75mm long strip at each end of the hip.



8. Cut the hip ridges to form a neat mitre junction at the ridge hip junction. Drill a hole near the mitre and mechanically fix each ridge with a screw to the batten. Seal all openings in the cut ridges with a roofing grade mastic sealant.

# Universal Dry Ridge Accessories



Universal Dry Ridge,  
Complete 6mt Kit



Ventilated Ridge Roll,  
Black & Terracotta



Ridge Batten Brackets



Clout Nails



Universal Ridge Union

Universal Ridge Union with Ratchet Clips



Ratchet Clip  
(Large Centre)



Ratchet Clip  
(Small Side)



Stainless Steel 100mm Screws

# Dry Hip System Hip Support Tray & Hip Clips

The **Universal Hip Support Tray** has been designed to support hip tiles along the hip line of the roof, without the need for mixing and carrying mortar to bed down the cut hip tiles. This provides a neat and level hip line when fixing the dry hip ridge tiles into position. The Hip Support Tray is a Dry Fix Product, and provides a secure and discreet solution once installed, and does not detract from the aesthetics of the roof.

### Installation

The roof is tiled on both sides of the hip as normal. Smaller cuts of tiles are secured by using our recommended **Hip Clips**. Starting at the eaves, roll out the Dry Ridge Roll centrally along the entire hip, neatly trimming the roll at the eaves, and tacking the roll at 500mm intervals using galvanised staples or felt nails. The protective tape is removed from the underside of the corrugated edge of the roll, and the butyl adhesive is pushed onto the tiles, which moulds to the profile of the tile, ensuring the vent roll is securely sealed along the entire hip on both sides.

The Hip Support Tray is trimmed at the eaves to suit the overhang of the bottom course of tiles or slates, and secured in place using suitable nails. Continue up the hip with the remaining trays, overlapping by 100mm at each join.

Once all the hip trays are in position, the hip ridges can be secured in place, following the smooth line of the Hip Support Trays. The Hip Support Tray can be used with the Universal Dry Ridge System, as well as most other similar hip kits on the market.



**Hip Clips** are designed to secure cut tiles on the hip, which then have no mechanical fixing. Hip Clips come in packs of 20 Large clips & 20 Small clips



<b>SIZE</b>	1200mm Long
<b>MATERIAL</b>	Re-constituted pvc
<b>PACK SIZE</b>	Pack of 10; Pallets of 500
<b>WEIGHT</b>	Pack of 10 : 6kg
<b>BENEFITS</b>	Lightweight, quick & easy to install, durable, A Dry Fix product, no need for mortar.

# Mortar bedded verge incorporating verge undercloak strip

The traditional approach to producing a weathertight verge is to butt joint flat strips of material ( undercloak) up the length of the last rafter, from eaves to ridge to support a bed of mortar. The verge should project 38mm to 50mm beyond the gable wall or barge board. The undercloak should be no less than 150mm wide over outer edge of bargeboard/gable wall. Slating battens should finish 25mm to 50mm from the outer edge of the undercloak.

The undercloak is gripped between the slating battens and either nailed to the bargeboard or flying rafter finishing 38mm to 50mm over outer edge of bargeboard/ gable wall. Slating battens should finish 25mm to 50mm from the outer edge of the undercloak, bedded in mortar of minimum 100mm width. Roofing mortar should be 1/3 cement sand with plasticiser. The mix should be based on sharp sand with soft sand added to achieve workability. The proportion of sharp sand should not be less than 1/3 of total sand content. If the verge is brick (i.e. no bargeboard) the undercloak must be set on a mortar bed.

The gap between the undercloak and the underside of the slates is filled with mortar to seal the gap and protect the slate batten ends from rain saturation. It is good practise to wet the underside of slates prior to bedding and to ensure all surfaces are clean and free from release agents used in manufacturing.



## Installation

The perimeter of the roof is the most vulnerable to wind suction loading. Secure fixing of the verge slates will contribute to creating a long lasting roof covering. The verge is formed from alternate courses of slate and a half (cut from double slates) and single slates. See page 51.

The initial verge slate (2nd under eaves course) should be a slate and a half. It will require an extra hole in the tail, half the slate distance in from the verge, 25mm from the base to accommodate the rivet for the first full slate in the next course.

The first full slate will also require an additional hole (batten gauge plus 25mm from the tail) to accommodate the rivet for the next slate and a half.

This next slate and a half will require three nail fixing holes on the batten line, two rivet holes to hold the tail and an additional hole to accommodate the rivet for the subsequent single verge slate.

When trimming to verges, valleys and hips avoid using pieces less than 150mm wide.

If possible use slate and a halves with the cut edges protected to prevent cement run off due to exposure to weather. At valleys and hips where raking cuts are required wide slates must be used to maintain adequate sidelap and bond. At the ridge or top abutment an additional batten is required between the final slate batten and the ridge/abutment to accommodate head nails for the final course of slates. This final course will generally be cut to length. The slates in the previous course may also need to be cut to length if the rafter length and batten gauge require it.

# Undercloak

## PRODUCT DETAILS

A light grey coloured strip used for mortar bedded verge and semi-exposed applications such as roofline soffit. This product meets the fire performance requirements of BS 476:1989 part 6 and BS476:1997 part

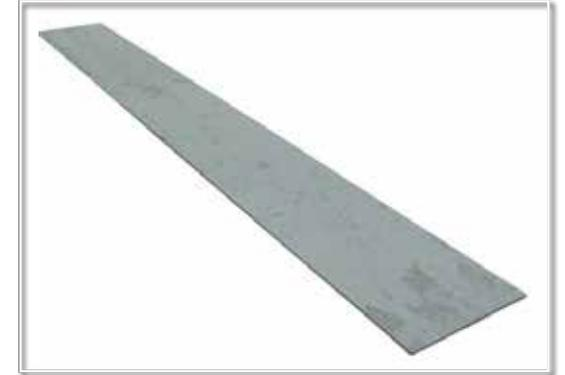

## Sizes available:

3.2mm thickness, 150mm wide x 1200mm lengths 1365 Per Pallet

4.5mm thickness, 150mm wide x 1200mm lengths. 1001 Per Pallet

A product which is popular on traditional verge details and semi-exposed applications, particularly when natural slate is used. Also commonly used on roof refurbishments.

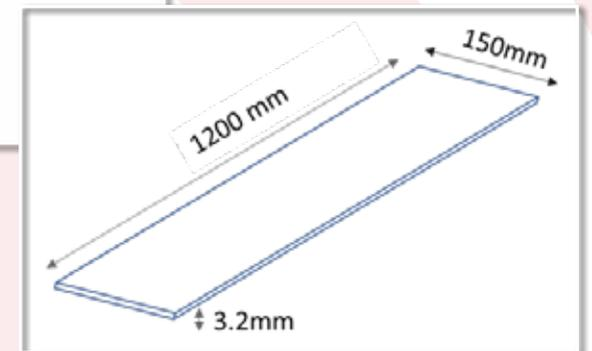
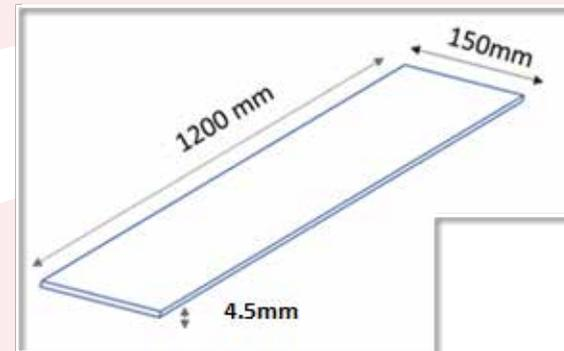

## Continuous Dry Verge



**Dry Valley Slate**



**Fast Fix Verge**



**3 in 1 Eaves System**



**Bird Comb**



**Roll Out Rafter**



**Universal Verge**



**EUROPEAN  
PLASTICS**

PLASTICS FOR THE BUILDING INDUSTRY

European Plastics Ltd, Unit 13, Brunel Industrial Estate, Cwmavon, Port Talbot. SA12 9DE

t: 01639 890578 f: 01639 890546 e: [info@europeanplastics.co.uk](mailto:info@europeanplastics.co.uk)

[www.europeanplastics.co.uk](http://www.europeanplastics.co.uk)